

Original instructions

# JSNY10

## Emergency stop grab wire safety switch

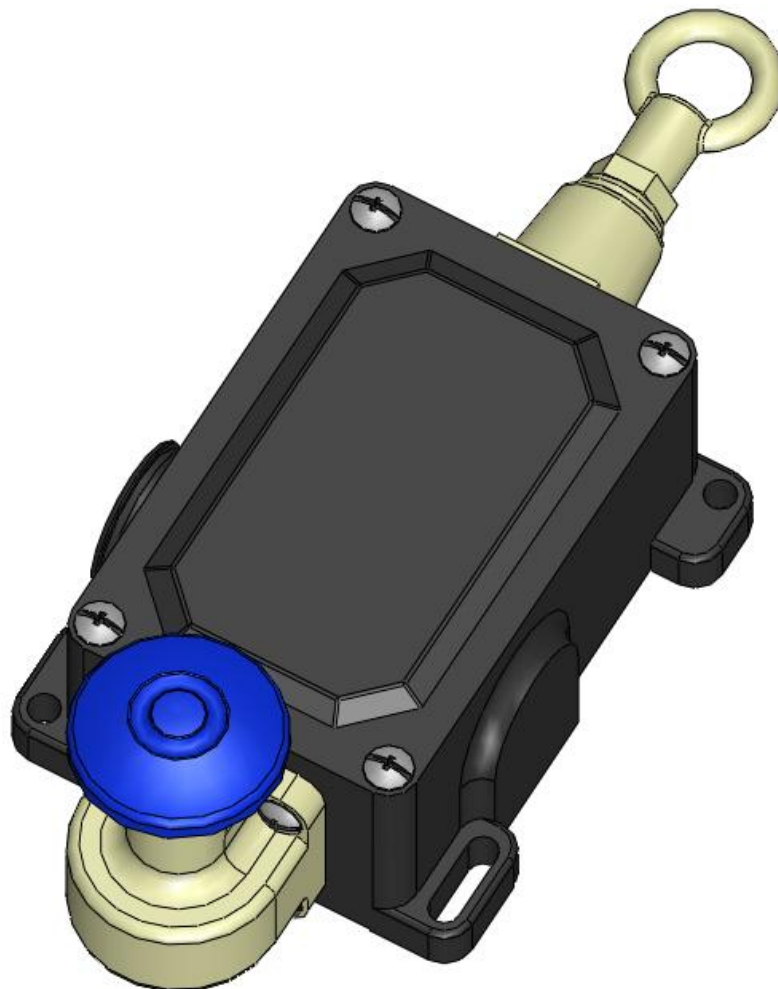

## Read and understand this document

Please read and understand this document before using the products. Please consult your ABB/JOKAB SAFETY representative if you have any questions or comments.

### **WARRANTY**

ABB/JOKAB SAFETY's exclusive warranty is that the products are free from defects in materials and workmanship for a period of one year (or other period if specified) from date of sale by ABB/JOKAB SAFETY.

ABB/JOKAB SAFETY MAKES NO WARRANTY OR REPRESENTATION, EXPRESSED OR IMPLIED, REGARDING NON-INFRINGEMENT, MERCHANTABILITY, OR FITNESS FOR PARTICULAR PURPOSE OF THE PRODUCTS, ANY BUYER OR USER ACKNOWLEDGES THAT THE BUYER OR USER ALONE HAS DETERMINED THAT THE PRODUCTS WILL SUITABLY MEET THE REQUIREMENTS OR THEIR INTENDED USE. ABB/JOKAB SAFETY DISCLAIMS ALL OTHER WARRANTIES, EXPRESSED OR IMPLIED.

### **LIMITATIONS OF LIABILITY**

ABB/JOKAB SAFETY SHALL NOT BE RESPONSIBLE FOR SPECIAL, INDIRECT, OR CONSEQUENTIAL DAMAGES, LOSS OF PROFITS OR COMMERCIAL LOSS IN ANY WAY CONNECTED WITH THE PRODUCTS, WHETHER SUCH CLAIM IS BASED ON CONTRACT, WARRANTY, NEGLIGENCE, OR STRICT LIABILITY.

In no event shall responsibility of ABB/JOKAB SAFETY for any act exceed the individual price of the product on which liability asserted.

IN NO EVENT SHALL ABB/JOKAB SAFETY BE RESPONSIBLE FOR WARRANTY, REPAIR, OR OTHER CLAIMS REGARDING THE PRODUCTS UNLESS ABB/JOKAB SAFETY'S ANALYSIS CONFIRMS THAT THE PRODUCTS WERE PROPERLY HANDLED, STORED, INSTALLED, AND MAINTAINED AND NOT SUBJECT TO ABUSE, MISUSE, OR INAPPROPRIATE MODIFICATION OR REPAIR.

### **SUITABILITY FOR USE**

ABB/JOKAB SAFETY shall not be responsible for conformity with any standards, codes, or regulations that apply to the combination of products in the customer's application or use of the product. At the customer's request, ABB/JOKAB SAFETY will provide applicable third party certification documents identifying ratings and limitations of use that apply to the products. This information by itself is not sufficient for a complete determination of the suitability of the products in combination with the end product, machine, system, or other application or use.

The following are some examples of applications for which particular attention must be given. This is not intended to be an exhaustive list of all possible uses of the products, nor is it intended to imply that the uses listed may be suitable for the products:

Outdoor use, uses involving potential chemical contamination or electrical interference, or conditions or uses not described in this document.

Nuclear energy control systems, combustion systems, railroad systems, aviation systems, medical equipment, amusement machines, vehicles, and installations subject to separate industry or government regulations.

Systems, machines, and equipment that could present a risk to life or property.

Please know and observe all prohibitions of use applicable to the products.

NEVER USE THE PRODUCTS FOR AN APPLICATION INVOLVING SERIOUS RISK TO LIFE OR PROPERTY WITHOUT ENSURING THAT THE SYSTEM AS A WHOLE HAS BEEN DESIGNED TO ADDRESS THE RISKS, AND THAT THE ABB/JOKAB SAFETY PRODUCT IS PROPERLY RATED AND INSTALLED FOR THE INTENDED USE WITHIN THE OVERALL EQUIPMENT OR SYSTEM.

### **PERFORMANCE DATA**

While every effort has been taken to ensure the accuracy of the information contained in this manual ABB/JOKAB SAFETY cannot accept responsibility for errors or omissions and reserves the right to make changes and improvements without notice. Performance data given in this document is provided as a guide for the user in determining suitability and does not constitute a warranty. It may represent the result of ABB/JOKAB SAFETY'S test conditions, and the users must correlate it to actual application requirements. Actual performance is subject to the ABB/JOKAB SAFETY Warranty and Limitations of Liability.

# Table of Contents

<b>1</b>	<b>Introduction</b>	<b>4</b>
	Scope	4
	Audience	4
	Prerequisites	4
	Special notes	4
<b>2</b>	<b>Overview</b>	<b>5</b>
	General description	5
	Safety regulations	5
	Function description	6
<b>3</b>	<b>Connections</b>	<b>7</b>
<b>4</b>	<b>Installation and maintenance</b>	<b>8</b>
	Safety instructions	9
	Maintenance	9
<b>5</b>	<b>Operation</b>	<b>10</b>
<b>6</b>	<b>Model overview</b>	<b>11</b>
	Accessories	11
<b>7</b>	<b>Technical data</b>	<b>12</b>
	Dimensions	13
	CAD model	13
<b>8</b>	<b>EC Declaration of conformity</b>	<b>14</b>

# 1 Introduction

## Scope

The purpose of these instructions is to describe the emergency stop grab wire safety switch JSNY10 and to provide the necessary information required for assembly, installation, checks and adjustments after installation, and maintenance.

## Audience

This document is intended for authorized installation personnel.

## Prerequisites

It is assumed that the reader of this document has knowledge of the following:

- Basic knowledge of ABB/Jokab Safety products.
- Basic knowledge of safety devices.
- Knowledge of machine safety.

## Special notes

Pay attention to the following special notes in the document:

 **Warning!** Danger of severe personal injury!  
An instruction or procedure which, if not carried out correctly, may result in injury to the technician or other personnel.

**Caution!** Danger of damage to the equipment!  
An instruction or procedure which, if not carried out correctly, may damage the equipment.

NB: Notes are used to provide important or explanatory information.

## 2 Overview

### General description

The JSNY10 can provide an easy to reach emergency stop along machines, transportation lines and processes. The device is easier to install than several individual emergency-stop buttons.

The JSNY10 can be utilised in several different ways to suit various applications e.g. the wire could be positioned at waist height along a transportation line, the emergency stop being activated if somebody walks into or falls onto the line or the wire could be positioned at head height making it easy to grab by anyone requiring to initiate an Emergency Stop.

### Safety regulations

#### Warning!

Carefully read through this entire manual before using the device.

The devices shall be installed by a trained electrician following the Safety regulations, standards and the Machine directive.

Failure to comply with instructions, operation that is not in accordance with the use prescribed in these instructions, improper installation or handling of the device can affect the safety of people and the plant.

For installation and prescribed use of the product, the special notes in the instructions must be carefully observed and the technical standards relevant to the application must be considered.

In case of failure to comply with the instructions or standards, especially when tampering with and/or modifying the product, any liability is excluded.

## Function description

The pulling gadget of the pull rope switching device gets connected with a steel rope. Pulling this rope will generate the Emergency-Stop function.

The JSNY10 has four contacts. When the switch is installed and the correct wire tension is set, all four contacts are closed. If the wire is pulled, two of the contacts open; if the wire breaks the other two contacts open. In both cases a dual channel machine stop signal will be given.

The JSNY10 can only be reset to normal operational mode through the integral mushroom-head slam button.

The contacts of the JSNY10 are forced disconnected which means that the contacts are mechanically pulled apart thus ensuring protection against contact welding/sticking.

The forced disconnected contacts provide a high level of safety. By combining the JSNY10 with a suitable ABB/Jokab Safety safety relay a high level of safety in respect of the connection of the machine control system is guaranteed. JSNY10 can be combined with Tina units for connection to a safety circuit with several safety components in accordance with the highest safety level.

## Construction

The rope pull switching device consists of a cast aluminium enclosure. It achieves protection class IP65 when the cover is closed properly and a cable gland matching the cable entry is installed. The device is equipped with two cable entries M20x1.5.

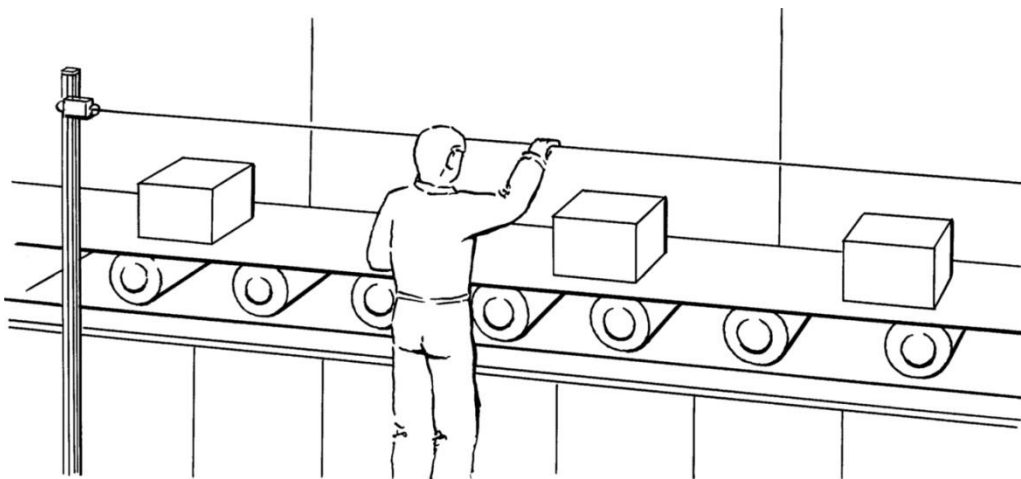

Emergency-stop Grab Wire easily accessible during normal work operation along a machine.

### 3 Connections

#### JSNY10 electrical connections

##### Connection example:

JSNY10 connected to RT6 safety relay.

NB: The connection shows the JSNY10 in a correctly tensioned condition.

##### Contacts description:

13-14: NC. Opens at wire rupture

25-26: NC. Opens when wire is pulled

33-34: NC. Opens at wire rupture

45-46: NC. Opens when wire is pulled

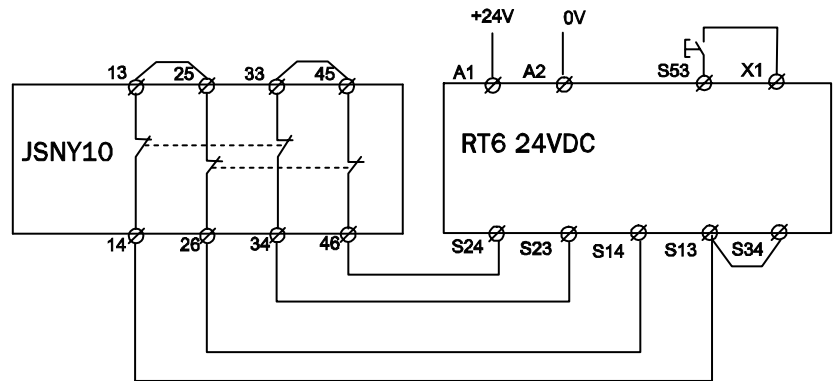

## 4 Installation and maintenance

Wire supports should be attached at a height of at least 20-25 mm above the surface where the switch is to be installed. Turnbuckles may be used to 'tune' the pull-wire system to the correct tension. A medium operating temperature should be maintained during installation. The wire should be pulled heavily several times, and then the tension of the wire should be readjusted to compensate for the elongation of the wire resulting from thimble distortion.

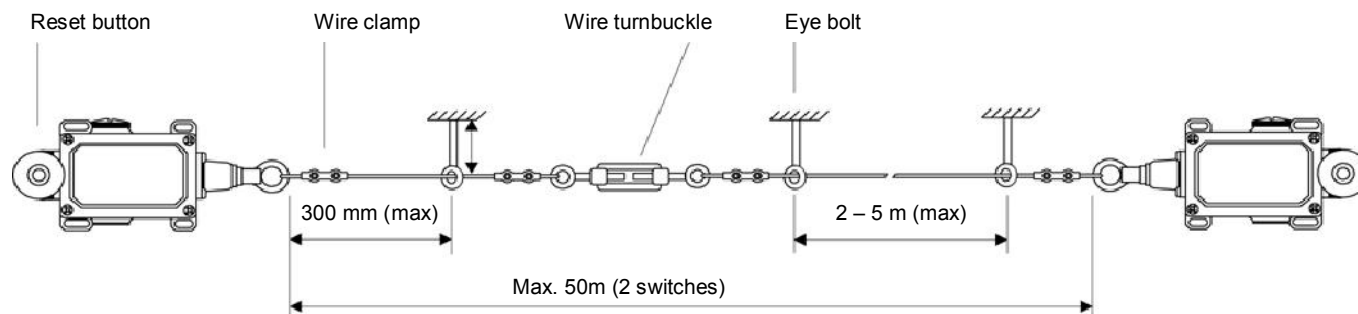

When the wire is installed with the correct tension all contacts are closed. Adjust the turnbuckle to get the correct tension; the scribed line on the axis of the JSNY10 should be just visible at the top of the socket.

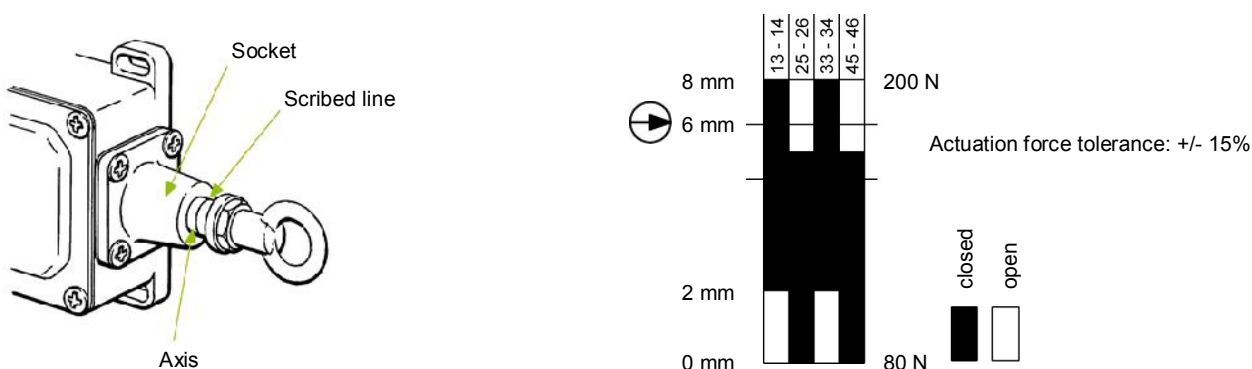

When an emergency stop condition occurs, switches 25-26 and 45-46 open, when the wire breaks contacts 13-14 and 33-34 open.

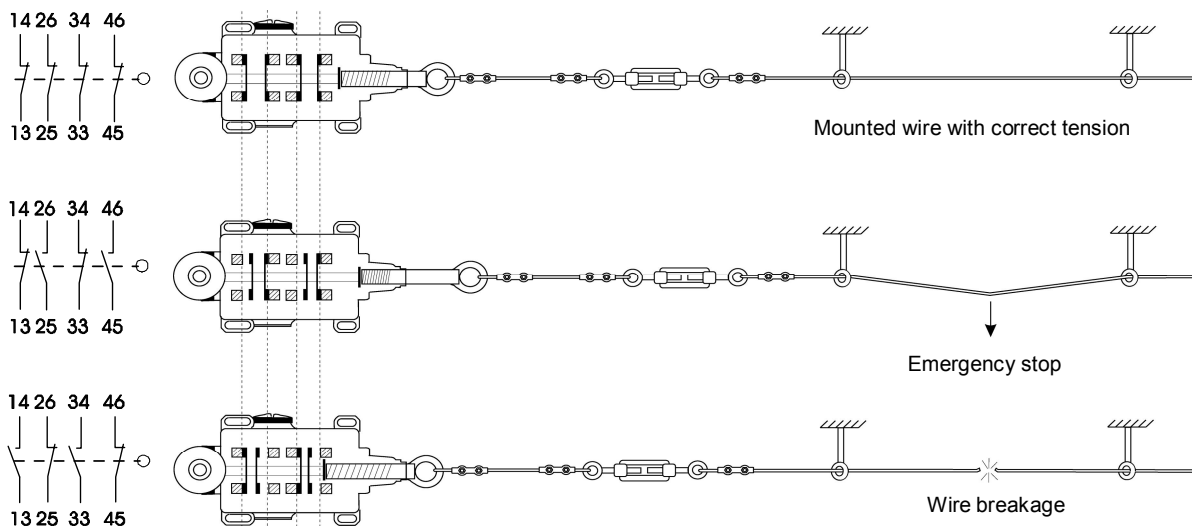



NB: During the installation special notice shall be given that fixing and clamping parts of the pull rope line do not obstruct the actuation of the rope pull switch. Enough space in between support and fixing elements shall be provided.

## Safety instructions

- All system parts have to be attached to such grounding machine parts which safely can accommodate the appearing forces.
- A straight guided rope will result in less friction force in the rope pull system. In rope pull systems with a system length of more than 25 m pulley blocks may only support the rope.
- If the rope gets deflected in the line (max. degree of deflection  $<180^\circ$ ) special pulley blocks have to be used.
- Positioning the rope supports in odd intervals prevents from rope vibrations which could lead to erratic tripping of the rope pull system.
- Sufficient space in between the rope supports will secure unmistakable grasp and actuation of the rope.

 **Warning!** An improper installation or manipulation of the rope pull switch will render the personal protection function useless and can cause serious or fatal injuries.

## Maintenance

NB: If the mushroom-head slam button is damaged it must be replaced in order to be able to reset an activated emergency stop. Contact the nearest ABB/Jokab Safety Service Office or reseller for further instructions.

- The tie pin shall be lubricated once a year with some grease free from resin and acid.
- The rope pull system shall be inspected and maintained in regularly intervals. The extent of the intervals depends from the ambient conditions and the operating conditions.
- Check the proper rope tension as well as the Emergency-Stop function of the pull rope and adjust if necessary.
- After maintenance or service the system function shall be tested through multiple actuations of the rope. Assure that the switching device latches duly and can be unlocked again.
- In case that the switch element or the latching device fails the complete rope pull switch must be replaced. The defective rope pull switch can be returned to the nearest ABB/Jokab Safety Service Office or reseller for inspection.

 **Warning!**

The safety functions and the mechanics shall be tested regularly, at least once every year to confirm that all the safety functions are working properly (EN 62061:2005).

In case of breakdown or damage to the product, contact the nearest ABB/Jokab Safety Service Office or reseller. Do not try to repair the product yourself since it may accidentally cause permanent damage to the product, impairing the safety of the device which in turn could lead to serious injury to personnel.

## 5 Operation

### Contacts

While the grab wire is not pulled or broken, the emergency stop is not activated and all contacts are closed. As soon as the grab wire is pulled or broken the emergency stop is activated. If the wire is pulled, contacts 25-26 and 45-46 are opened. If the wire breaks, contacts 13-14 and 33-34 are opened.

### Reset

To reset an activated emergency stop, the mushroom-head slam button must be pushed.

## 6 Model overview

Type	Article number	Description
JSNY10	2TLJ020034R0000	JSNY10 emergency stop grab wire safety switch

### Accessories

Type	Article number	Description
JSNY10	2TLJ020034R0000	Switch
Kit K1	2TLJ020034R0700	Mounting kit, 25 m
Wire W3	2TLJ020034R0500	Wire, plastic coated, red, 3 mm / 4 mm (core/sleeve) per meter
Bolt S6	2TLJ020034R0200	Eye bolt M6x50
Nut M6	2TLJ020034R0100	Nut M6 (to eye bolt)
Turnbuckle V6	2TLJ020034R0600	Wire turnbuckle M5x50
Clamp L3	2TLJ020034R0400	Wire clamp, duplex
Thimble T4	2TLJ020034R0300	Wire thimble
Swivel R5	2TLJ020034R1300	Swivel for wire

## 7 Technical data

Manufacturer	
Address	ABB AB / JOKAB SAFETY Varlabergsvägen 11 SE-434 39 Kungsbacka Sweden
Article number/ordering data	2TLJ020034R0000
Electrical characteristics	
Rated insulation voltage	400 VAC
Conventional thermal current	16 A
Utilization category	AC-15/DC-13
Short-circuit protection	16 A delay fuse, 20 A quick fuse
General	
Protection class	IP65, EN 60529
Ambient temperature	-30...+80°C
Size	See drawing
Weight	700 g
Material	Housing: Cast aluminium Lid: Aluminium
Colour	Black with yellow label
Contacts	4 NC (2 forced)
Cable access	2 x M20 x 1.5
Terminals	Screw terminal, 8 x M4
Mounting	4 x M5
Mechanical life	10 <sup>6</sup> switch operations
Max. switching frequency	20/min
Reset method	Mushroom-head slam button
Max. wire length	25 m
Safety / Harmonized standards	
Conformity	European Machinery Directive 2006/42/EC <b>CE</b> EN ISO 12100-1,-2, EN 954-1, EN ISO 13849-1, EN 60204-1, EN ISO 13850
EN ISO 13849-1	B <sub>10d</sub> : 100,000
Certifications	CSA A 300

## Dimensions

### JSNY10 dimensions

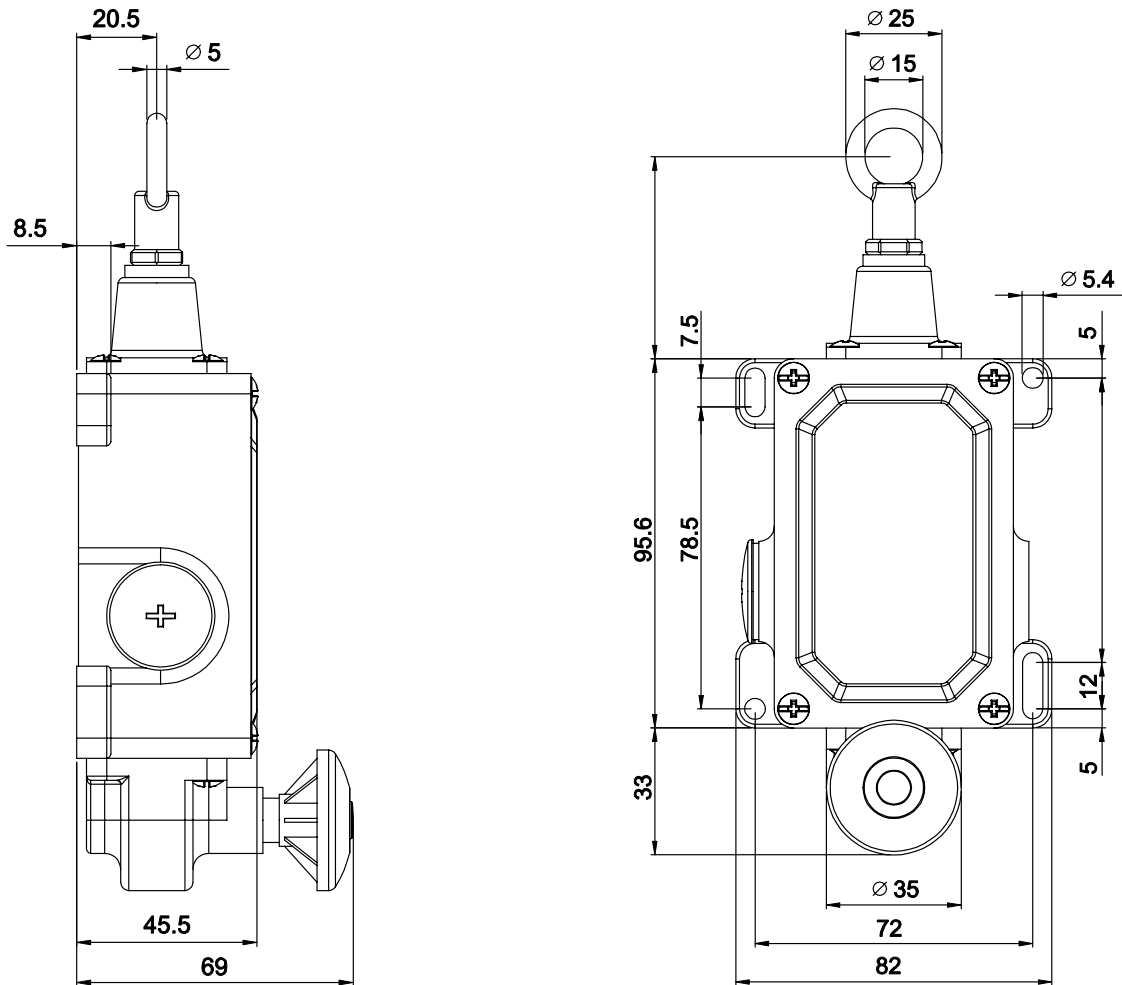

NB: All measurements in millimetres.

### CAD model

- 1) Visit [www.jokabsafety.com](http://www.jokabsafety.com).
- 2) Choose language **English** in the menu at the top of the page.
- 3) In the menu to the left, choose **Products**.
- 4) A list of products is now shown. Choose **3D CAD files**. This will open a new window called "Jokab Safety AB – SolidComponents".
- 5) In the new window there is a menu to the left, showing different product categories. JSNY10 belongs to the category **Emergency stops**, find it in the list and click it. If the language changed in the new window, click the corresponding flag at the top of the page to choose language again (Swedish, English or German available).
- 6) Choose **JSNY10** in the list now shown.
- 7) Choose a preferred format in the scroll down list next to "CAD-format" (SolidWorks, ProE, Sat, Step, Parasolid, Iges, Dwg, Dxf).
- 8) Click the **save icon** in front of the product ("Stop").
- 9) The product will now be added to the list of downloads. Click the **save icon** again in the new list to start the download.

## 8 EC Declaration of conformity



### EC Declaration of conformity

(according to 2006/42/EC, Annex2A)

We	ABB AB JOKAB SAFETY Varlabergsgatan 11 SE-434 39 Kungsbacka Sweden	declare that the safety components of ABB AB make with type designations and safety functions as listed below, is in conformity with the Directives
		2006/42/EC 2006/95/EC
Person authorised to compile the technical file	Lars-Magnus Felth ABB AB JOKAB Safety Varlabergsgatan 11 SE-434 39 Kungsbacka Sweden	
<b>Product</b>		<b>Certificate</b>
Emergency stop device Smile, versions 10EA, 10EAK, 11EA, 12EA, 11EAR		11-SKM-CM-0103
Emergency stop device INCA 1		11-SKM-CM-0103
Emergency stop wire Stop Line		
Emergency stop wire JSNY10		
Notified Body	Inspecta Sweden AB Box 30100 SE-104 25 Stockholm Sweden	
	Notified Body No. 0409	
Used harmonized standards	EN ISO 12100:2010, EN 954-1:1996, EN ISO 13849-1:2008/AC:2009, EN 60204-1:2007+A1, EN ISO 13850:2008	

Mats Linger  
PRU Manager  
Kungsbacka 2011-03-04

---

[www.abb.com](http://www.abb.com)  
[www.jokabsafety.com](http://www.jokabsafety.com)

Original

ABB AB / JOKAB SAFETY Varlabergsvägen 11, SE-434 39 Kungsbacka, Sweden

[www.jokabsafety.com](http://www.jokabsafety.com)